

000-1501

		REVISIONS		APPROVED	DATE
ECO NUMBER	REVISION	REV DESCRIPTION			
11336	A	DRAWING RELEASE		EDG	4/2/2007

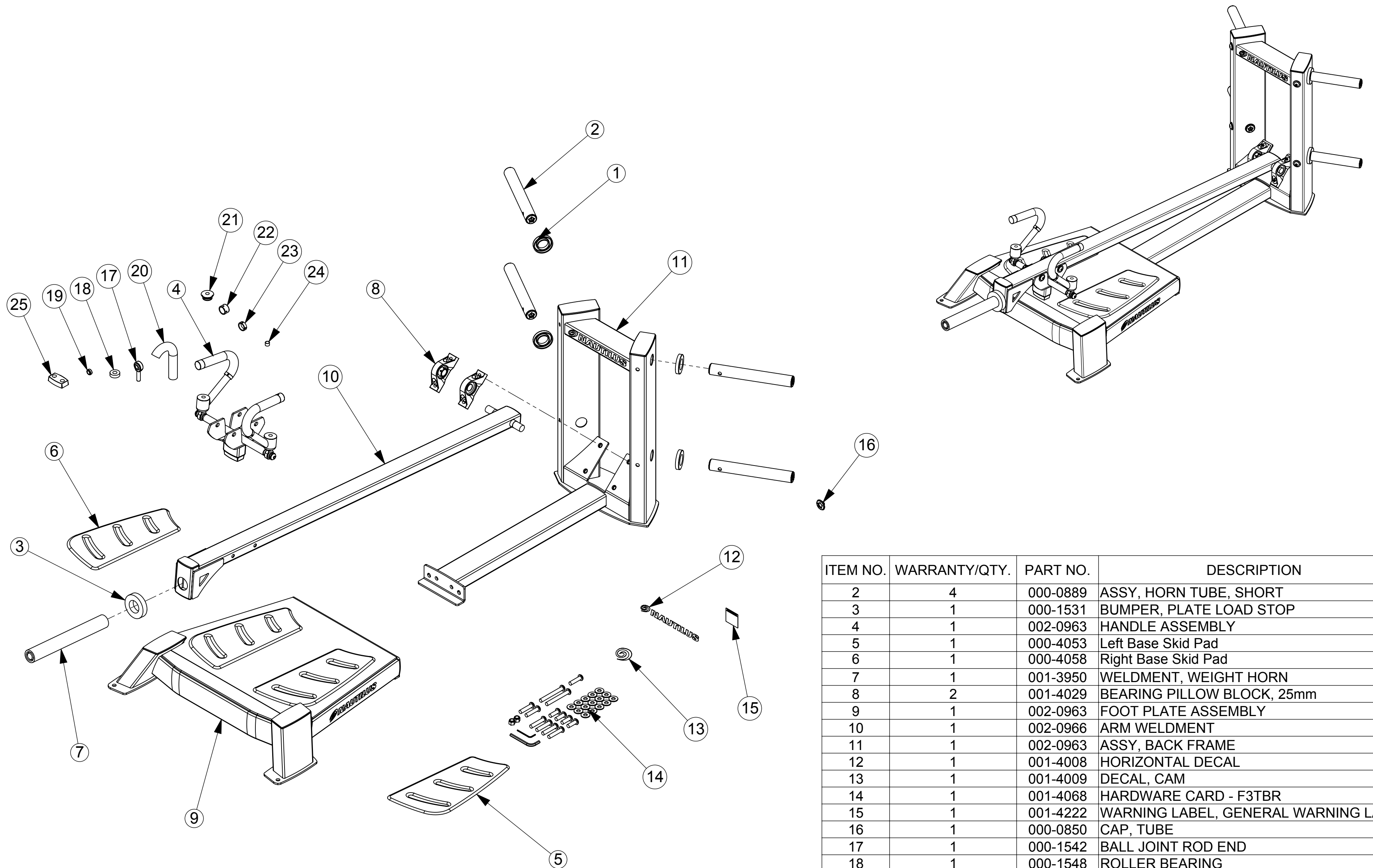

ITEM NO.	WARRANTY/QTY.	PART NO.	DESCRIPTION
2	4	000-0889	ASSY, HORN TUBE, SHORT
3	1	000-1531	BUMPER, PLATE LOAD STOP
4	1	002-0963	HANDLE ASSEMBLY
5	1	000-4053	Left Base Skid Pad
6	1	000-4058	Right Base Skid Pad
7	1	001-3950	WELDMENT, WEIGHT HORN
8	2	001-4029	BEARING PILLOW BLOCK, 25mm
9	1	002-0963	FOOT PLATE ASSEMBLY
10	1	002-0966	ARM WELDMENT
11	1	002-0963	ASSY, BACK FRAME
12	1	001-4008	HORIZONTAL DECAL
13	1	001-4009	DECAL, CAM
14	1	001-4068	HARDWARE CARD - F3TBR
15	1	001-4222	WARNING LABEL, GENERAL WARNING LABEL
16	1	000-0850	CAP, TUBE
17	1	000-1542	BALL JOINT ROD END
18	1	000-1548	ROLLER BEARING
19	1	000-1549	NYLON SPACER, ROD END
20	1	000-1534	GRIP, UNIVERSAL HANDLE
21	1	000-1518	CAP, BEARING HOUSING
22	1	000-1513	HANDLE CAPS
23	1	000-1535	RING, HANDLE ENDS
24	1	001-3874	BOLT SLEEVE
25	1	001-4041	BUMPER STOP ASSEMBLY
27	2	902-2483	NUT-NL 0500-13 G5-BIKZ

NAUTILUS
 NAUTILUS, INC.
 16400 SE NAUTILUS DRIVE, VANCOUVER, WA 98683
 CONTACT J.SALAZAR@nautilus.com / 303.545.1439

DESIGNED	J.HARRACH	TITLE	T-BAR ROW	
DRAWN	S.MCCARTY	SIZE	PART NO.	000-1501
DATE	12/28/2006			REV. A01
ALL APPLICABLE NAUTILUS STANDARDS AND SPECIFICATIONS APPLY.				