

000-1551

ECO		REVISIONS		APPROVED	DATE
11336	A	REV DESCRIPTION	DRAWING RELEASE	EDG	3/29/2007

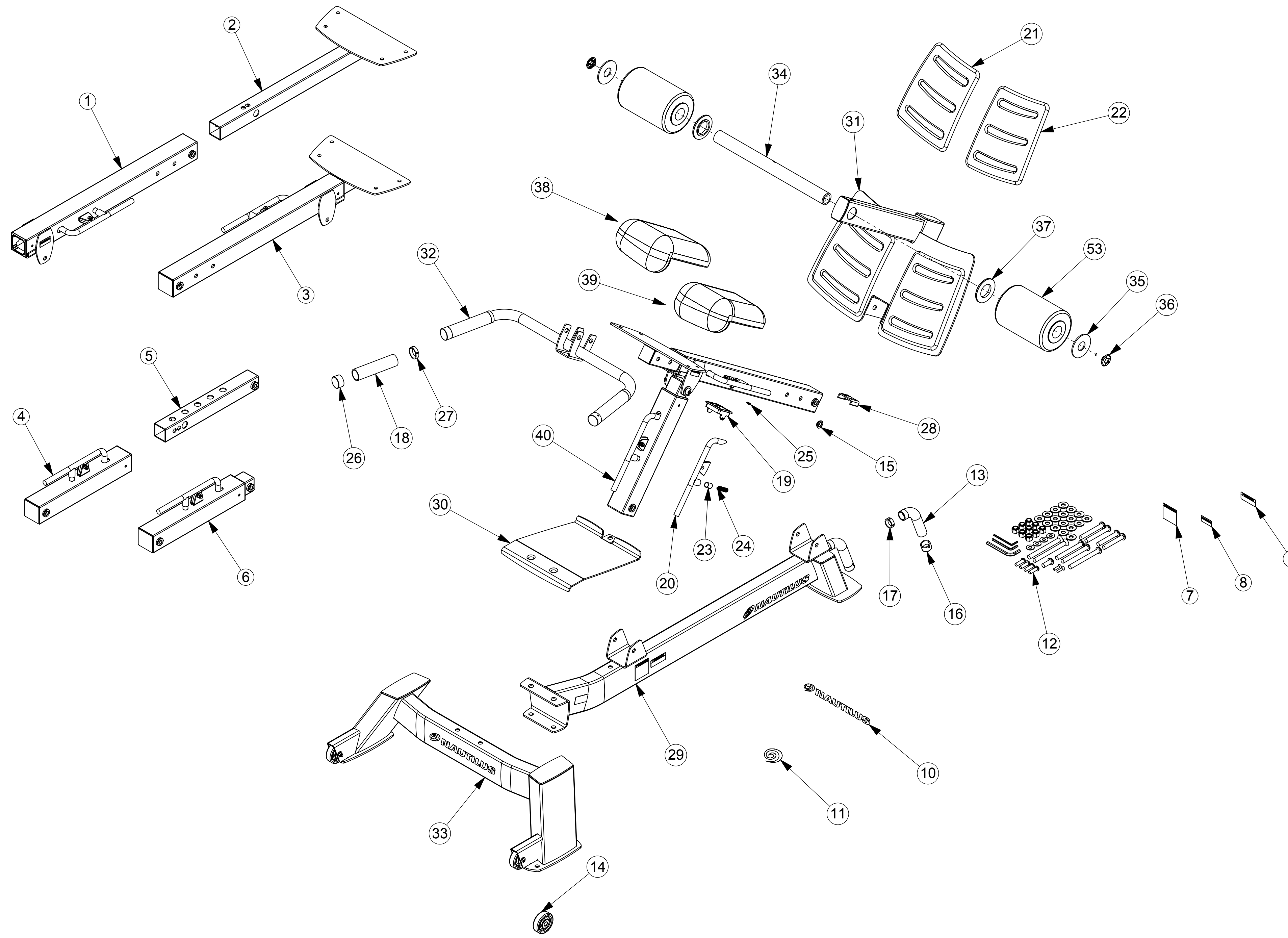

ITEM	WARRANTY/QTY.	PART NO.	DESCRIPTION
1	1	000-1568	ASSEMBLY, EXTENSION ADJUSTMENT
2	1	000-1567	WELDMENT, HIP PAD
3	1	001-4114	REAR TELESCOPING ASSEMBLY
4	1	000-1569	ASSEMBLY, ANGLE ADJUSTMENT
5	1	001-4112	FRONT INSIDE TELESCOPING ASSEMBLY
6	1	001-4113	FRONT TELESCOPING ASSEMBLY
7	1	001-4222	WARNING LABEL, GENERAL WARNING LABEL
8	1	001-4225	WARNING LABEL
9	1	001-4220	WARNING LABEL #6
10	1	001-4008	HORIZONTAL DECAL
11	1	001-4009	DECAL, CAM
12	1	001-4074	HARDWARE CARD - F3AHE
13	1	000-0721	RUBBER HANDLE GRIP
14	1	000-0722	WHEEL, 70mm
15	1	000-1286	BUSHING, PIVOT
16	1	000-1513	HANDLE CAPS
17	1	000-1535	RING, HANDLE ENDS
18	1	000-1584	HANDLE GRIP
19	1	000-1586	SLIDER FOR 50MM TUBE
20	1	000-1597	WELDMENT, ADJUSTMENT ARM
21	1	000-4142	Right Leg Press Foot Pad
22	1	000-4143	Left Leg Press Foot Pad
23	1	001-3869	SLEEVE, SPRING STOP
24	1	001-3870	SPRING, HANDLE
25	1	001-3871	BUSHING, ADJUSTMENT
26	1	001-3872	HANDLE CAPS
27	1	001-3873	RING, HANDLE ENDS
28	1	001-3994	SLIDE BUSHING- F2 HIP EXTENSION
29	1	002-3402	BACK FRAME ASSEMBLY
30	1	000-1570	PLATE, WEIGHT HOLDER
31	1	001-4111	FOOT PLATE ASSEMBLY
32	1	002-3402	HANDLE ASSEMBLY
33	1	002-3402	FRONT LEG ASSEMBLY
34	1	000-1312	ROLLER SHAFT ASSEMBLY
35	2	000-1065	WASHER, BUMPER END
36	2	000-0850	CAP, TUBE
37	2	000-1068	PAD FLANGE
38	1	001-3921	HIP PAD ASSEMBLY, RIGHT
39	1	001-3925	HIP PAD ASSEMBLY, LEFT
40	1	002-3402	FRONT AND REAR TELESCOPING ASSEMBLY
53	2	001-4691	ASSY, THIGH ROLLER

**NAUTILUS, INC.**  
 16400 SE NAUTILUS DRIVE, VANCOUVER, WA 98683  
 CONTACT J.SALAZAR@nautilus.com / 303.545.1439

DESIGNED	J.HARRACH	TITLE	<b>MAIN ASSY, F3AHE, ADJ. HIP EXT</b>	
DRAWN	S.MCCARTY	SIZE	<b>D</b>	REV. <b>A01</b>
DATE	1/04/2007	PART NO.	<b>000-1551</b>	
ALL APPLICABLE NAUTILUS STANDARDS AND SPECIFICATIONS APPLY.		SCALE:	1:25	SHEET 1 OF 2

This document is the property of Nautilus, Inc. It may not be reproduced in whole or part, provided to third parties, or used for any purposes other than the performance of work for Nautilus, Inc. without written authorization. All rights are reserved, including copyrights.